

6P9	-0,012
	-0,042
6h8	0
	-0,018

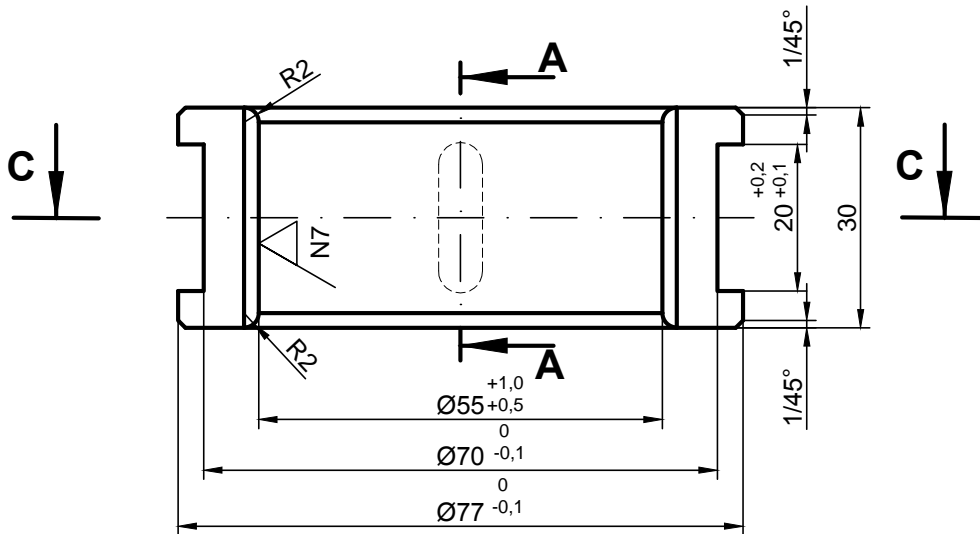

PRESEK "B-B"



PRESEK "C-C"

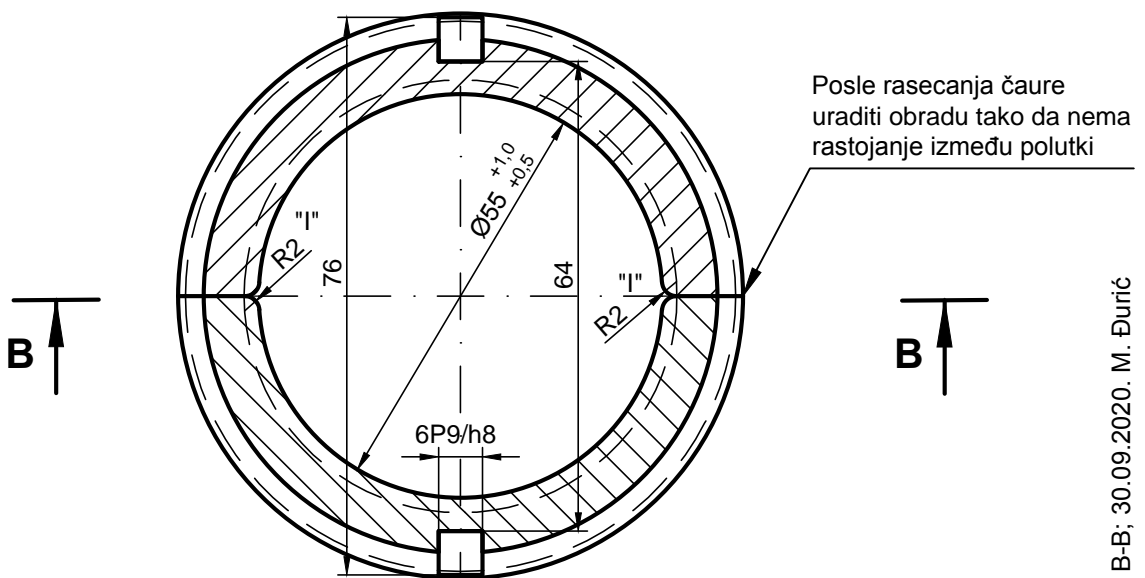

PRESEK "A-A"

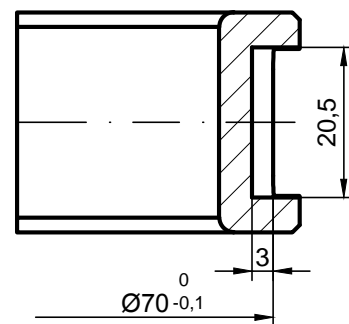

NAPOMENA :

- cementirati na dubinu 1,5mm, tvrdoće 55 ±2 HRC,
- obrađene površine namazati mašću,
- oboriti sve oštre ivice,
- čaure isporučiti sa 2 klina 6x6x20mm.

"I" izmena; ucrtan radijus R2 na preseku B-B; 30.09.2020. M. Đurić

Čaura dvodelna jednodnog cilindričnog para

Blok A3

KOM.	NAZIV	POZ.	MATERIJAL	BR. CRTEŽA SKLOPA	DIMENZIJA	BR. CRTEŽA ILI STANDARDA
2		Č.4321	548.22.411.	Ø77/Ø55x30		
TE "NIKOLA TESLA" OBRENOVAC	RAZMERA	DATUM	CRTAO	Z. Simić	BROJ CRTEŽA	
		18.07.2018.	KONSTRUISAO	M. Đurić	548.22.413.	